

BASC 32-100



Robust tie rod design

Oil bearing is adopted so the piston rod do not need to be lubricated

Besides fixed buffer, the cylinder terminal has adjustable cushion screw so that the cylinder enters stably during commute direction

The cylinder piston is equipped with a permanent magnet that can trigger the magnetic switch of the cylinder to detect the moving position of cylinder

The seal material with high temperature resistance is adopted to guarantee the normal operation of cylinder at 150°C

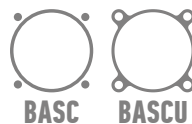

TECHNICAL DATA

BORE[Φ]	32	40	50	63	80	100
Pneumatic connection	G1/8"	G1/4"	G1/4"	G3/8"	G3/8"	G1/2"
Piston rod thread	M10×1.25	M12×1.25	M16×1.5	M16×1.5	M20×1.5	M20×1.5
Cushioning	Adjustable at both ends					
Cushioning length[mm]	18	18	18	18	24	24
Operating temperature	-5-70°C					
Operating pressure	12 bar					
Operating medium	Filtered compressed air,with or without lubrication					
Version	Double acting					
Type of mounting	Via accessories					
Mounting position	Any					

1 bar=0.1MPa=14.5PSI

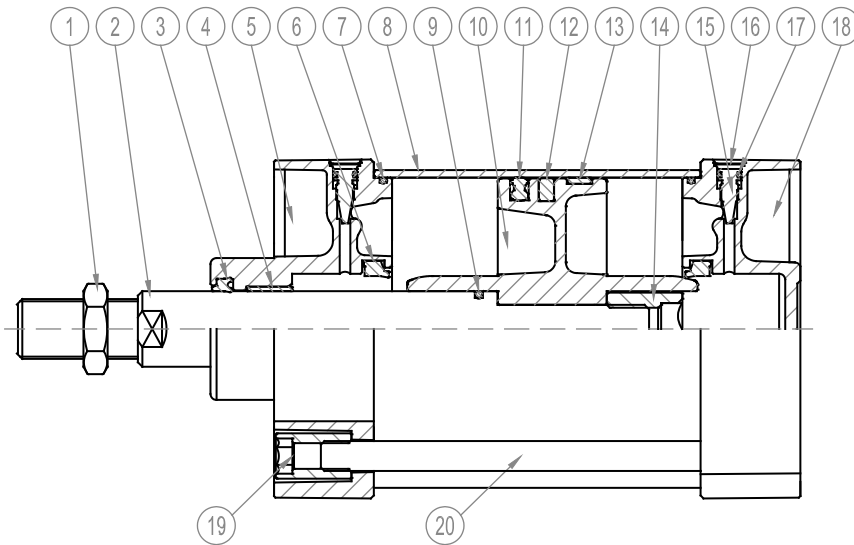

1	Nut, Piston rod	Carbon steel
2	Piston rod	C45 chrome-plated steel
3	Wiper seal	NBR
4	Oil bearing	Steel
5	Front cover	Die cast aluminium
6	Cushioning seal	NBR
7	O-ring, Front cover	NBR
8	Tube	Anodized aluminium
9	O-ring, Piston rod	NBR
10	Piston	Die cast aluminium
11	Piston seal	NBR
12	Magnet	Ferrite
13	Wear Ring	POM
14	Piston rod lock nut	Carbon steel
15	Cushion adjustment screw	Brass
16	Snap ring, Cushion screw	Spring steel
17	O-ring, Cushion screw	NBR
18	End Cover	Die cast aluminium
19	Tie-rod nut	Nickel-plated steel
20	Tie rod	A3

KEY CODE

BASC **D** - **50** **X** **50** - **25** - **S** - **SA** - **P** - **2** **4** - **LB** - **I**

BASC	D	50	50	25	S	SA
SERIES	TYPE	BORE	STROKE [mm]	ADJUSTABLE STROKE	MAGNETIC	VERSION
BASC=With tie rod	Blank=Standard	32-40-50-63-80-100	As request	As request	Blank=Without magnet S=With magnet	SA= Single acting
BASCU=Without tie rod	D=Double rod type					DA= Double acting
J=Double rod type with adjustable stroke						

P	2	4	LB	I
THREAD TYPE	PISTON ROD MATERIAL	TIE ROD MATERIAL	MOUNTING TYPE	CONNECTOR TYPE
P=PT Thread	Blank=Carbon steel	Blank=Carbon steel	Blank=Without accessory	Blank=Without accessory
N=NPT Thread	2=316 Stainless steel	4=316 Stainless steel	LB=Angle bracket	I=I joint
G=G Thread			FA=Flange	Y=Y joint
			CA=Male clevis	U=Rod eye joint
			CB=Female clevis	F=Floating joint
			LNG=Square hinge	

PS: High temperature seals available upon request

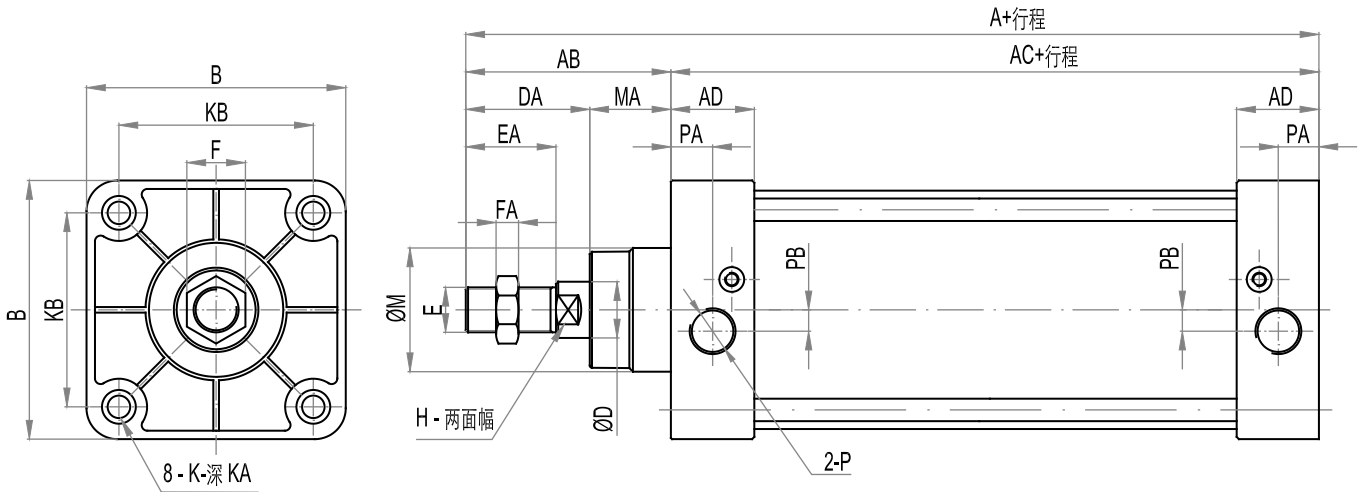
BASC Standard Type

Φ [MM]	32	40	50	63	80	100
A	140	142	150	153	183	189
AB	47	49	57	57	75	75
AC	93	93	93	96	108	114
AD	27.5	27.5	27.5	27.5	33	33
B	45	50	62	75	94	112
D	12	16	20	20	25	25
DA	32	34	42	42	54	54
E	M10×1.25	M12×1.25	M16×1.5	M16×1.5	M20×1.5	M20×1.5
EA	22	24	32	32	40	40
F	17	19	24	24	26	26
FA	6	7	8	8	8	8
H	10	14	17	17	22	22
K	M6×1	M6×1	M6×1	M8×1.25	M10×1.5	M10×1.5
KA	9.5	9.5	9.5	9.5	11.5	11.5
KB	33	37	47	56	70	84
M	28	32	38	38	47	47
MA	15	15	15	15	21	21
P	G1/8"	G1/4"	G1/4"	G3/8"	G3/8"	G1/2"
PA	14	14	14	14	16.5	16.5
PB	35	6	85	7	10	11

BASCD Double rod type

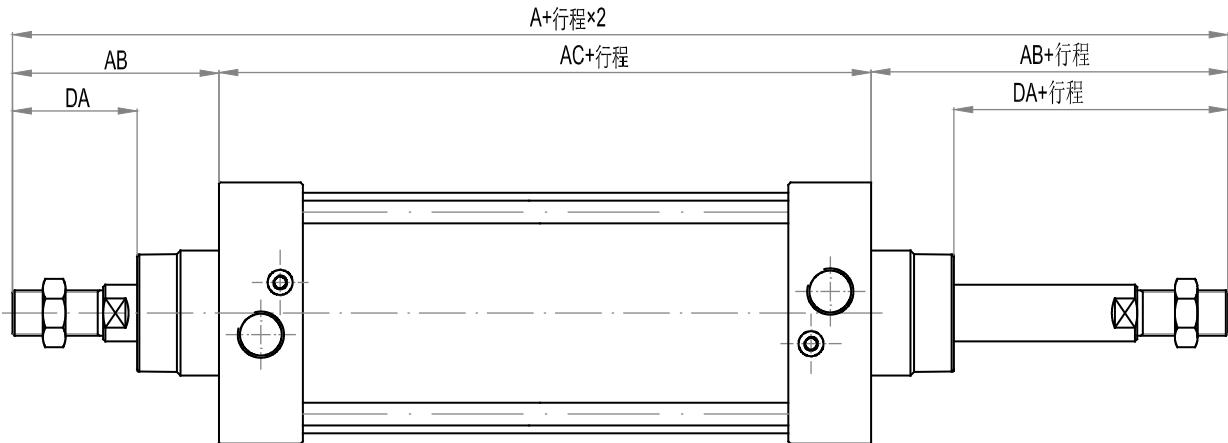

BASCJ Double rod type with adjustable stroke

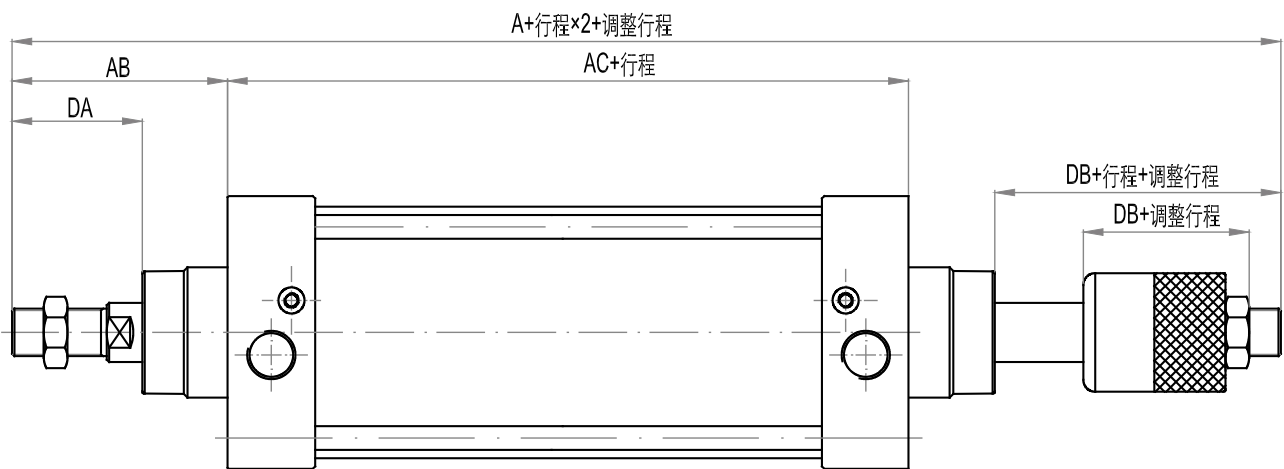

Φ [MM]		32	40	50	63	80	100
A	BASCD	187	191	207	210	257	264
	BASCJ	182	185	196	199	243	249
AB		47	49	57	57	75	75
AC		93	93	93	96	108	114
DA		32	34	42	42	54	54
DB		21	21	23	23	29	29
E		M10×1.25	M12×1.25	M16×1.5	M16×1.5	M20×1.5	M20×1.5

MOUNTING ATTACHMENTS AND ACCESSORIES

Φ	LB	FA/FB	CA	CB	I	Y	U
32	●	●	●	●	●	●	●
40	●	●	●	●	●	●	●
50	●	●	●	●	●	●	●
63	●	●	●	●	●	●	●
80	●	●	●	●	●	●	●
100	●	●	●	●	●	●	●

More are available in accessories. Cover kits and service kits are available